

FLAME PASSIVE SENSOR

FP-2500E



**FLAME DETECTION AT 10m(33ft.) AND INTRUSION DETECTION WIDE ANGLE 10m(33ft.), WITH COMPACT DESIGN!
IDEAL COMBINATION SENSOR TO MINIMIZE NUISANCE ALARM AND REALIZE SAFER INDOOR PROTECTION OF YOUR PREMISE**

TWO OUTPUT MODES SELECTABLE

Two output modes are available; "AND" detection mode and "Individual" detection mode.

- In "AND" detection mode, an alarm signal is output when both flame and passive infrared sensor detect during the selected AND timer.
- In "Individual" detection mode, flame or passive alarm signal is output when either the flame sensor or passive sensor detects.

FORCED OUTPUT OPERATION

The flame sensor outputs flame alarm signal after continued detection for a certain period of time, or detects twice during the selected AND timer even in "AND" detection mode, without any detection by passive sensor.

ALARM MEMORY

It can be easily identified by Alarm memory indication (flame and passive sensor individually) which sensor is activated. Memory LED blinks for 3 min. and lights on for 47 min. after alarm activation.

PET IMMUNITY (Passive Sensor)

Multiple Zone Technology ensures 40 lbs. (20kg) pet immunity with outstandingly high performance and reliability.

AREA ADJUSTMENT (Passive Sensor)

The coverage pattern can be adjusted to different mounting heights by moving the inner unit.

OPERATION SET-UP BY DETECTION TIMER (Flame Sensor)

The alarm will be activated only when the sensor detects a flame (ultraviolet rays) for longer time than set time. Two detection times are selectable by DIP switch on the sensor. < 1 sec., 3 sec. >

FLAME PASSIVE SENSOR

Detection area

■ Wide Angle
unit : m

Setting conditions
Detection timer : 1sec.
Origin of flame : Gas lighter
Size of flame : Approx. 2.75"(7cm)

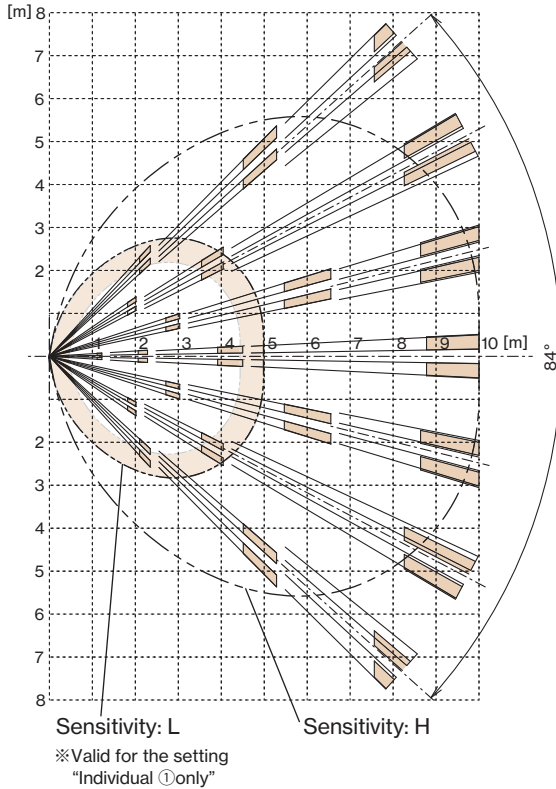

External dimensions

Unit : inch (mm)

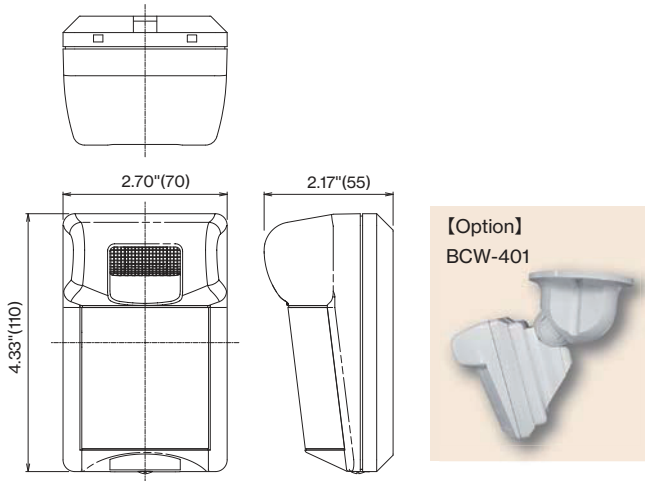

Terminal configuration

POWER	ALARM① (FLAME)	ALARM② (PASSIVE)	TAMPER
10 to 30VDC 20mA non-polarity	30V(AC/DC) 0.25A N.C./N.O.	30V(AC/DC) 0.1A N.C.	

Allowable wiring distance between sensor and power source

Size of wire	Distance at 12VDC
AWG 22 (Dia. 0.65mm)	830 ft. (250m)
AWG 20 (Dia. 0.80mm)	1470 ft. (450m)
AWG 18 (Dia. 1.00mm)	2300 ft. (700m)

•The maximum wire length, when two or more units are connected, is the above distance divided by the number of units.

TAKEX

Please note :

This sensor is designed to detect intrusion and to initiate an alarm; it is not a burglary or a crime preventing device. TAKEX is not responsible for damage, injury or losses caused by accident, theft, Acts of God (including inductive surge by lightning), abuse, misuse, abnormal usage, faulty installation or improper maintenance.

Specifications

Product name	FLAME PASSIVE SENSOR
Model No.	FP-2500E
Detection system	Ultraviolet rays (Detection wave length 185 to 260nm)
Detection distance	33'(10m) , 2.75"(7cm) lighter flame in front
Detection area angle	Approx. 120° conically
Detection setting	Detection timer (1sec, 3sec) Detection sensitivity (H [100%], L[50%]) *Detection sensitivity can be set at only "Individual" mode. *H[100%] is fixed at "AND" mode.
Alarm LED (RED)	Part of flame sensor • Lighting at alarm (Detection time + off delay. Approx. 2 sec.) • Blinking (3 min) and Lighting (47 min) at memory
Detection system	Passive infrared
Detection area	Wide Angle 33'(10m) Max. 29 pairs
Detection area angle adjustment	3 steps
Alarm LED (RED)	Part of passive sensor • Lighting at alarm (One shot, Approx. 2 sec.) • Blinking (3 min) and Lighting (47 min) at memory • Lighting at trouble.
Power supply	10V to 30VDC (non-polarity)
Current consumption	20mA Max.
Alarm output	Individual mode Flame sensor output (From ALARM① terminal) • Dry contact relay (Semi-Conductor) (N.O./N.C. selectable) • Contact operation : Detection time + off delay. (Approx. 2 sec.) • Contact capacity : 30V (AC/DC) 0.25A Max. (resistive load) Passive sensor output (From ALARM② terminal) • Dry contact relay (Semi-Conductor) (N.O./N.C. selectable) • Contact operation : One shot (Approx. 2 sec.) • Contact capacity : 30V (AC/DC) 0.25A Max. (resistive load) AND mode Forced flame signal output (From ALARM① terminal) When the flame sensor detects a flame twice during the selected AND timer. (Detection time + off delay. Approx. 2 sec.) Or When the flame sensor continues to detect a flame for flame duration time 15 or 30 sec. (Detection time after 15/30 sec + off delay. Approx. 2 sec.) • Dry contact relay (Semi-Conductor) (N.O./N.C. selectable) • Contact capacity : 30V (AC/DC) 0.25A Max. (resistive load) AND detection signal output (From ALARM② terminal) When both passive and flame sensors detect during the selected AND timer. (Detection time, Min. 2 sec.) • Dry contact relay (Semi-Conductor) (N.O./N.C. selectable) • Contact capacity : 30V (AC/DC) 0.25A Max. (resistive load)
Tamper output	Dry contact relay N.C. (Activated when the front cover is detached) Contact capacity : 30V (AC/DC) 0.1A Max. (resistive load)
Alarm memory	Reset after blinking (3 min) and lighting (47 min) (Operate flame and passive LED individually)
Ambient temperature range	5°F to +131°F (-15°C to +55°C) without condensation
Mounting position	Indoor wall surface (Ceiling with option attachment "BCW-401")
Connections	Self-up terminal
Weight	Approx. 120g
Appearance	Resin

Maintenance

- Check the operation once a week.
- Do not fail to check operation whenever a furniture in the place is moved in and out of detection area.

When housing is stained, remove the stain with a soft cloth using water or mild detergent.

Do not use such chemicals as thinner or benzene to clean the housing.