

TURNSTAR

RELIABLE ★ DURABLE ★ GUARANTEED

TITAN FULL HEIGHT INDUSTRIAL TURNSTILE



- The TITAN is a high security, aesthetic choice for your entrance
- It provides a high level of perimeter security
- Exported worldwide



TITAN FLAT PACK VERSION
(FOR LOW COST SHIPPING)



ULTRA LOW
POWER CONSUMPTION
0.25W

APPLICATIONS

- Suited for applications requiring high volume access and high levels of security
- Used extensively in applications such as mines, factories, warehouses, colleges, building sites and stadiums

DESIGNED FOR

- Interior and exterior installations
- Severe operating conditions

AVAILABLE CONFIGURATIONS

- 3 arm (120°) and 4 arm (90°)
- Single and double

SECURITY RATING



ISO 9001:2015

WHAT YOU NEED TO KNOW WHEN BUYING A TURNSTILE

IN TERMS OF THE PRICE, IS THE TURNSTILE SUPPLIED COMPLETE OR ARE THERE ANY HIDDEN EXTRAS?

Turnstar units are supplied 100% complete. Control panels are ready for power and data connections. Reader mounting brackets are available for full height turnstiles for the mounting of biometric systems, access readers, ticketing equipment, pushbuttons and coin or token acceptors.

WHAT ARE THE RUNNING COSTS?

With a long-established reputation for being exceptionally reliable and durable, Turnstar turnstiles are built to give years of cost-free and fault-free service with no routine maintenance. Our products are a fit-and-forget solution.

IS THIS TURNSTILE ROBUST ENOUGH FOR THE JOB? AM I GOING TO HAVE FAILURES DURING SERVICE?

Turnstar products are designed for the harshest of environments and have become the standard for Africa's mining industry, which is known for extreme operating conditions. Production is carried out by state-of-the-art CNC machinery and robotic welding, all of which provide products of the highest quality and to the tightest of tolerances.

HOW LONG IS THE GUARANTEE AND IS THIS AN EXTRA COST?

Turnstar's industry leading ten-year guarantee is included in the purchase price.

WHAT DOES THE GUARANTEE COVER?

All mechanical components, including ratchet disk and locking pawls, are covered by the Turnstar ten-year guarantee. The control panel, microswitches and solenoids are covered by a one-year guarantee.

CAN YOU TRUST THE TURNSTILE SUPPLIER?

Established in 1990, Turnstar has manufactured and sold over 50 000 turnstiles. Our customers range from the world's largest blue chip corporations to single-site retailers. As one of the world's leading manufacturers, we have an unrivalled reputation for outstanding products backed by superior customer service.

WILL THE TURNSTILE WORK WITH ALL TYPES OF ACCESS SYSTEMS?

Turnstar turnstiles operate with all forms of electronic access control, ticketing and time and attendance systems. In addition, they can be operated with pushbutton controls, remote transmitters and coin or token acceptors.

WHAT WILL HAPPEN TO THE TURNSTILE IN THE EVENT OF A POWER FAILURE?

The turnstile can be factory-set for either fall-secure (auto-lock on power failure) or fall-safe (auto-unlock on power failure) operation. The turnstile can also be unlocked by means of the mechanical key override which is supplied standard with the turnstile. A battery backup system is also available on request, which will provide normal operation under conditions of no power.

WHAT OTHER PRODUCTS ARE AVAILABLE WITH THE TURNSTILE

Turnstar manufactures standard and special design reader mounting brackets as well as pedestrian gates and security barriers for use with all our turnstiles. We also supply special colours, and manufacture turnstiles in custom sizes and designs.

WHERE CAN I FIND OUT MORE ABOUT THE UNBEATABLE VALUE FROM TURNSTAR?

Go to www.turnstar.co.za for more information on our product range, projects and blog.



UNIQUE FEATURES OF THE TITAN TURNSTILE RANGE

ROTALOK® ROTATION LOCKING MECHANISM

- CE conformity
- Ultra heavy-duty electromechanical rotation locking mechanism
- Bi-directional operation
- Designed by professional engineers
- Tried, tested and perfected over a period of over 20 years

RELIABLE TECHNOLOGY

- Suspended rotor technology - eliminating stress on the base bearing
- Self-centering rotation system - rotor returns to starting position after every rotation
- Shock absorbing rubber coupling system
- Anti-Trap® safety system - no mid-rotation locking or trapping in the event of a power failure
- Programmable logic with user diagnostic features
- Mechanical key override - clockwise and anti-clockwise directions (fail-secure)

DURABLE FEATURES

- Zinc plated for corrosion resistance
- Ultra quiet, buffered solenoids and pawls
- Solenoids rated for 100% duty cycle
- Case hardened locking disk and pawls - eliminating any wear
- Factory settings need no further adjustment
- No routine maintenance whatsoever, ever

GUARANTEED MANUFACTURED TO LAST

- 10 year mechanical guarantee
- 1 year electrical guarantee

ROTARUN® PERPETUAL BASE BEARING

- Fitted to all TITAN turnstiles

RELIABLE TECHNOLOGY

- Combination of stainless steel and self-lubricating engineering plastics

DURABLE FEATURES

- Designed for the harshest of conditions
- 100% corrosion resistant
- Unaffected by dust, dirt or moisture
- Self-lubricating

GUARANTEED MANUFACTURED TO LAST

- Zero maintenance
- 10 year mechanical guarantee

TECHNICAL SPECIFICATIONS

POWER	220 Volt AC (110 Volt AC on request)
FREQUENCY	50Hz / 60Hz
POWER CONSUMPTION (STANDBY)	0.25W (single turnstile) 0.5W (double turnstile) - fail-secure mode
POWER CONSUMPTION (STANDBY)	50W (single turnstile) 100W (double turnstile) - fail-safe mode
SOLENOID VOLTAGE	24 Volt DC (12 Volt DC on request)
LOGIC VOLTAGE	24 Volt DC
DIMENSIONS	Single turnstile: <ul style="list-style-type: none">• 1 400mm wide x 2 125mm high• 1 430mm wide x 2 250mm high – recommended minimum opening size Double turnstile: <ul style="list-style-type: none">• 2 150mm wide x 2 125mm high• 2 180mm wide x 2 250mm high – recommended minimum opening size
ROTOR DIAMETER	1 200mm
ROTOR ARM CONFIGURATION	3 arm (120°) 4 arm (90°)
ROTOR ARMS	50mm diameter tube arms spaced 120mm apart
WEIGHT	Single turnstile (4 arm): 160kg Double turnstile (4 arm): 255kg
DESIGN	Modular bolt-together design for ease of transport and installation. Components can pass through a standard door. Can be packed in broken-down form either onto a pallet or into a crate for transport. Flat pack version allows for greater space saving during transport.
SYSTEMS INTEGRATION	<ul style="list-style-type: none">• Integrates with all access control and time & attendance systems• Unlocking for entry / exit rotation controlled through normally open dry contact• Transaction / rotation complete output• Integral wireways with draw wires in place - no exposed wires

MANUFACTURING OPTIONS

ROTATION OPTIONS	<ul style="list-style-type: none">• Electrically controlled bi-directional rotation (factory standard)• Mechanically controlled uni-directional rotation by means of key override• Free rotation
LOCKING OPTIONS	<ul style="list-style-type: none">• Fail-secure auto-lock on power failure (factory standard)• Fail-safe auto-unlock on power failure• Each direction of rotation configurable for either fail-secure or fail-safe operation
FIRE ALARM OPTIONS	Free rotation when triggered indefinitely
POWER OPTIONS	<ul style="list-style-type: none">• Battery backup with two 12 volt 7Ah batteries connected in series<ul style="list-style-type: none">• Up to 5 500 transactions in fail-secure mode• Up to 270 minutes operation in fail-safe mode• Solar panel with charge controller and battery system
FLAT ROOF CANOPY OPTION	<ul style="list-style-type: none">• Provides protection from the elements• Anti-climb protection• Low energy light on underside of canopy
SPECIAL PHYSICAL DESIGN OPTIONS	<ul style="list-style-type: none">• Restrictor tubes for increased security (4 arm turnstile only)• 180° rotation setting for extra walkthrough space (4 arm turnstile only)• Special narrow single turnstile design for 1 200mm wide opening• Special split cover for low ceilings• Special internal mechanism dust cover for dirty environments• Heavy-duty base for portability (with forklift channels)
ACCESSORY OPTIONS	<ul style="list-style-type: none">• Card / proximity reader mounting bracket• Biometric / fingerprint reader mounting brackets• Single / double pushbutton in plastic housing• LCD transaction counter with reset key switch• Random search device
FINISH OPTIONS	<ul style="list-style-type: none">• Mild steel with UV resistant polyester exterior powder coat finish (charcoal blue hammertone) ■• Mild steel with hot dip galvanised finish ▲• 304 grade brushed stainless steel• 316 grade brushed stainless steel ▲ <p>▲ suitable for highly corrosive environments (details available on request) ■ other colours available on request</p>

STAR QUALITIES



- 1 Rotalok® rotation locking mechanism and electronic control panel - incorporates:
 - Anti-Trap® safety system
 - Suspended Rotor technology
 - Mechanical key override
 - Shock absorbing rubber coupling
- 2 Lockable top cover
- 3 50mm diameter tube arms spaced 120mm apart
- 4 Access control reader mounting position
- 5 Rotarun® perpetual base bearing
- 6 Wiring side entry point
- 7 Wiring bottom entry point
- 8 Floor bolting positions - 7 off
- 9 Wall bolting positions - 2 off

THE TITAN RANGE



TITAN 3 SINGLE



TITAN 3 DOUBLE



TITAN 4 SINGLE



TITAN RANGE

TITAN SINGLE RANGE

A	Recommended opening width	1 430mm
B	Turnstile width	1 400mm
C	Recommended opening height	2 250mm
D	Turnstile height	2 125mm
E	Headroom	1 986mm

TITAN DOUBLE RANGE

A	Recommended opening width	2 180mm
B	Turnstile width	2 150mm
C	Recommended opening height	2 250mm
D	Turnstile height	2 125mm
E	Headroom	1 986mm

TITAN 3 SINGLE

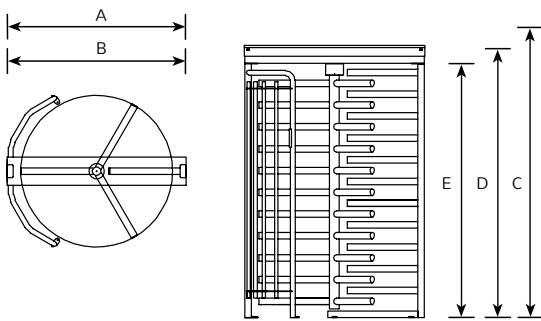

TITAN 3 DOUBLE

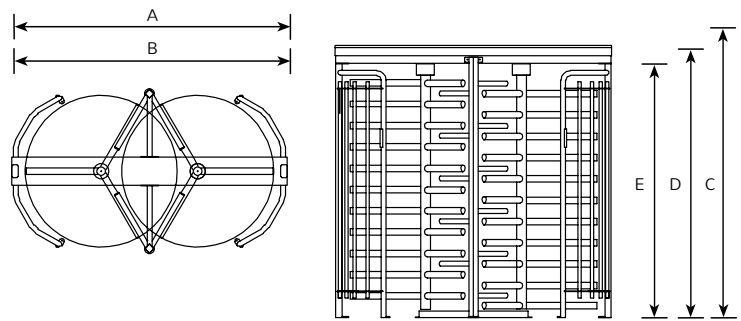

TITAN 4 SINGLE

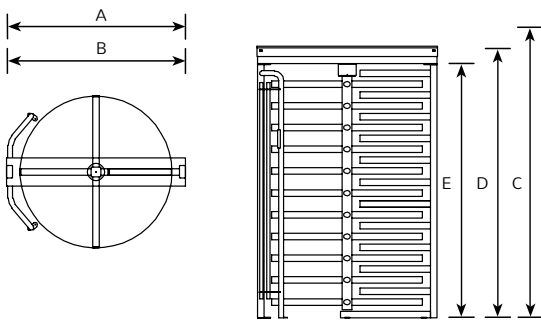

TITAN 4 DOUBLE

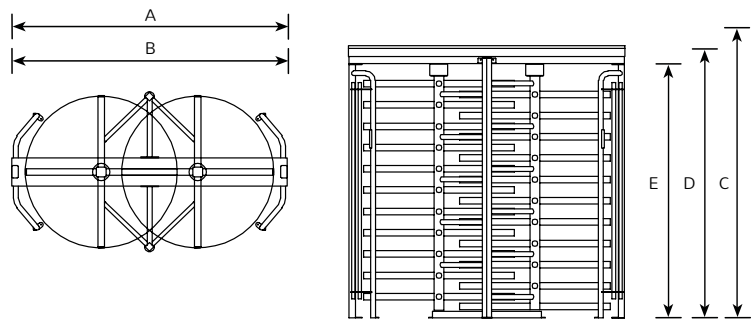

Due to our policy of continuous improvement, products are subject to change without notice.
Custom designs available on request

© Turnstar Systems



ISO 9001:2015