

12.8V - 7.0Ah Lithium LiFePO4 Battery

XTREME Series Lithium Iron Phosphate batteries are powerful LiFePO4 products that have the highest capacity in standard casings available on the market. The highly sophisticated and integrated BMS with very low self-consumption brings safety, functionality and ease of use together in a lightweight and robust casing. The batteries have been specifically designed to provide energy for RV (Recreational Vehicles), marine, solar and backup power systems. Bluetooth and LED indicators, LCD screen, self-heated functions could be optional.



Benefits of Lithium

- High capacity, low weight, Increased energy in given space
- Fast charging
- High operational reliability
- Safest lithium technology
- Excellent life cycles
- Built-in intelligent BMS to protect the battery pack and prolong its service life
- Maintenance free

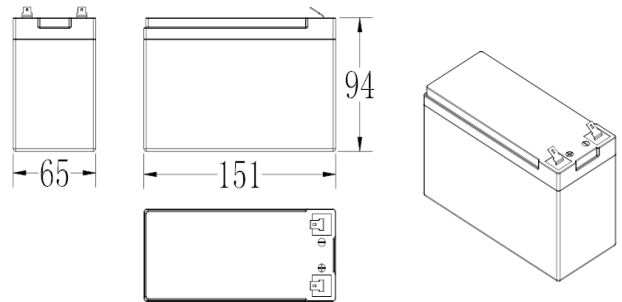

Certifications and standards

a.Products

- UL1642(cells)
- FCC
- UN38.3
- IEC62619

b.MS certifications

- ISO9001
- ISO14001
- OHSAS 18001

Specifications

Nominal Characteristics		
Battery model		TP1207LFP
Nominal voltage		12.8V
Typical capacity		7.0Ah(25°C,0.2C)
Typical energy		89.6Wh
Cells type/chemistry		Prismatic-LiFePO ₄
Gravimetric Energy density		95.4Wh/Kg
Dimensions	Length	94mm
	Width	65mm
	Height	151mm
Reference Weight		0.94Kg
Case Material		ABS
Cycle life		>2000 cycles (100% DoD)
Electrical Characteristics		
Charge method		CC/CV
Charge voltage Range		14.3~14.6V
Max.continuous Discharge Current		10A
Max.continuous Charge Current		7A
Discharge Pulse Current (10 sec)		20A
End of Discharge Voltage		10V
Operation Environment		
Charge Temperature		0°C~55°C
Discharge Temperature		-20°C~60°C
Storage Temperature		-20°C~60°C
Protection Class		IP56

BMS specifications

ITEM	CONTENT	CRITERION
Voltage	Charging voltage	3.65V/cell
	Balance voltage	3.45V/cell
Current	Max continues charge current	7A
	Max continues discharge current	10A
Over charge Protection	Over charge detection voltage	3.75±0.05V
	Over charge detection delay time	1~3S
	Over charge release voltage	3.6±0.05V
Over discharge Protection	Over discharge detection voltage	2.5±0.05V
	Over discharge detection delay time	1~3S
	Over discharge release voltage	2.70±0.10V
Over current protection	Over discharge current protection	33A
	Detection delay time1	50~150mS
	Over charge current detection current	14A
	Detection delay time	300~800mS
Short Circuit Protection	Short Circuit Protection Current	130A, External short circuit
	Detection delay time	400uS
	Release condition	Cut load and charging
Battery temperature	Over-temperature protection	65±5°C
	Release temperature	50±5°C

Performance curve

